

Greenzone Aluminium Greenhouse

Code:AA9DSN002XXXXX

ASSEMBLY INSTRUCTION

Overall assembled size : L130 x W190 x H195 (cm)

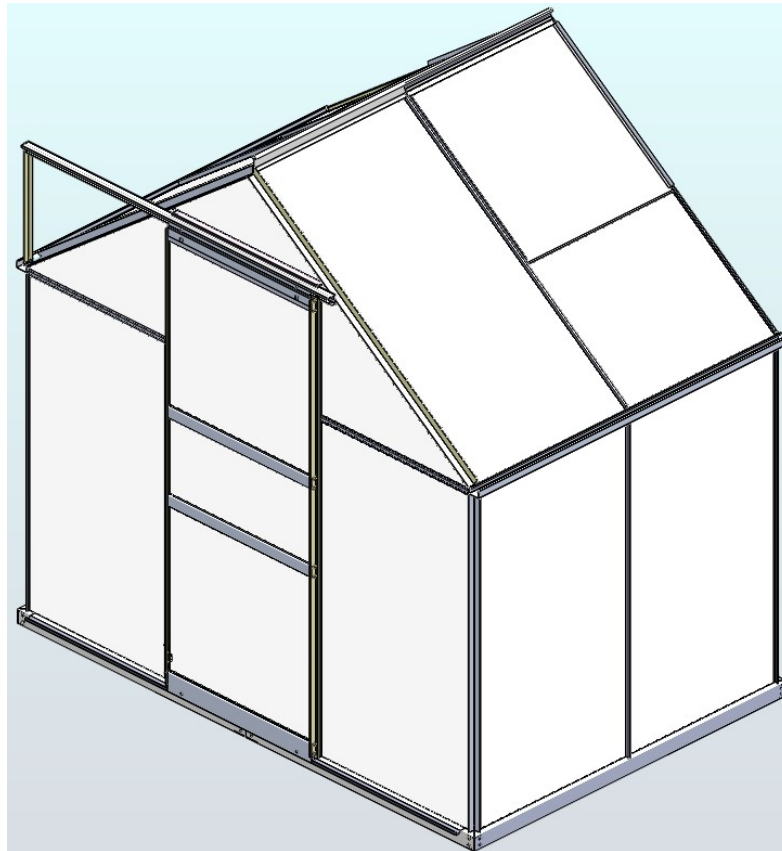

Please read all instructions carefully before assembly.

It is best to familiarize yourself with the parts and

Collate the appropriate parts for each step.

SAFETY ADVICE

We strongly recommend the use of work gloves during assembly.

Do not attempt to assemble the Aluminum greenhouse in windy or wet conditions, Do not touch overhead power cables with the aluminum profiles.

Always wear shoes and safety goggles when working with extruded aluminum.

Dispose of all plastic bags safely and keep them out of reach of children.

The Aluminum greenhouse must be positioned and fixed on a flat level surface.

Do not lean against or push the Aluminum Greenhouse during construction.

Keep children away from the assembly area.

Do not position your Aluminum greenhouse in an area exposed to excessive wind.

Do not attempt to assemble this Aluminum greenhouse if you are tired ,have taken drugs or alcohol or if you are prone to dizzy spells.

If using a step ladder or power tools ensure that you follow the manufactures safety advice.

Hot items such as recently used grills, blowtorches etc. must not be stored in the Wall shed.

Ensure there are no hidden pipes or cables in the ground before inserting the pegs.

GENERAL ADVICE

This is a multi-part assembly, allow at least 3-4 hours for assembly.

In selecting a site-choose a sunny level position away from overhanging trees.

If you are fixing your Aluminum Greenhouse directly to a solid concrete foundation use the pre drilled holes in the metal base supplied.

The component parts should be checked and laid out close at hand.

Keep all small parts(screws etc) in a bowl so they do not get lost.

Keep roof clear of snow and leaves.

CARE & MAINTENANCE

When your Aluminum greenhouse needs cleaning, use a mild detergent solution and rinse

Do NOT use acetone, abrasive cleaners or other special detergents to clean the clear panels.

Recommendations for Tools

Protective Equipment:

- 1.Safety Helmet
- 2.Gloves
- 3.Goggles







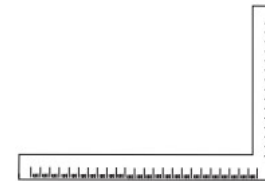
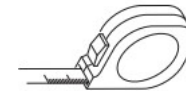



















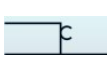









Measuring Tools & Installation Equipment:









- 1.Tape Measure
- 2.Angle Rule
- 3.Triangular Ladder
- 4.SpannerC10
- 5.Cross Screwdriver
- 6.Marking Pen
- 7.Mallet

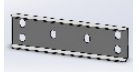

Aluminum Parts:

MODEL	CODE	LENGTH (mm)	QTY	MODEL	CODE	LENGTH (mm)	QTY	MODEL	CODE	LENGTH (mm)	QTY	MODEL	CODE	LENGTH (mm)	QTY
	C1301A	1551	1		C501	1150	4		C101A	1606	1		C2201	621	2
	C1301B	1551	1		C201	1150	2		C101B	1606	1		C2202	610	3
	C1801	590	1		C2503	1286.2	2		C203A	1622	1				
	C701	600	1		C2001	1310	2		C203B	1622	1				
	C1101	600	2		C2004	616	2		C1902	628	2				
	C2301	600	1		C2005	635	1		C202	1137	2				
	C2401	607	2		C2103	1234.2	1		C1001	405.5	1				
	C2601	602	2		C503A	1157	1		C401	606	1				
	C2701	600	4		C503B	1157	1		C601	1275	1				
	C801	971.3	1		C503C	1157	1		C2002	1253	4				
	C802	815.9	1		C503D	1157	1		C2003	610	2				



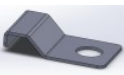



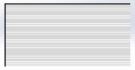
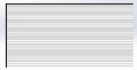

AdaptingPiece:

MODEL	CODE	LENGTH (mm)	QTY	MODEL	CODE	LENGTH (mm)	QTY
	CBJ01	948.8	1		CBJ07	138*69	4
	CBJ03	948.8	1		CBJ09	150*44	1
	CBJ05	948.8	1		CBJ10	30*40	4
	CBJ06	948.8	1		CBJ11	100*44	1
	BJ02	1299.2	2				2
	CBJ14	50*30	4				

Hardware:

MODEL	CODE	LENGTH (mm)	QTY
	C1	28	1
	C2		4
	C4		120
	D1	M6X9*3.5	122
	C5		2
	C3		3
	D2	M6X16	2
	D3	M6X40	2
	D4	M4X10	5
	D5	ST4. 2X9.5	10
	D6	ST4. 8X19	18
	D7	M6-GB41	124
	D8	M10*100	4

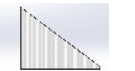
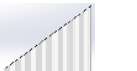
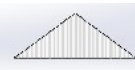
Twin PC Board:

MODEL	CODE	LENGTH (mm)	QTY	MODEL	CODE	LENGTH (mm)	QTY
	K001	562*598	2		A001	1148*617	4
	K002	261*598	1		A003	1150*617	2
	M001	628*604	2		A002	534*617	2
	E003	1146*621	2		D003	1146*610	3
	E002	454*621	2		D001	470*610	2
	E001	240*650	1		D002	698*610	1

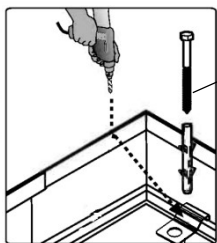
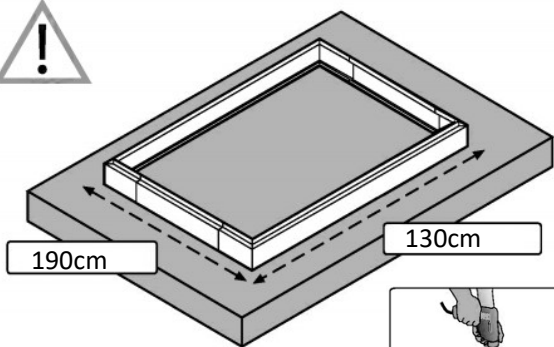
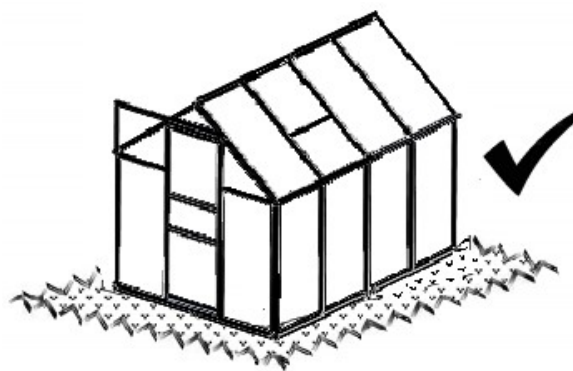
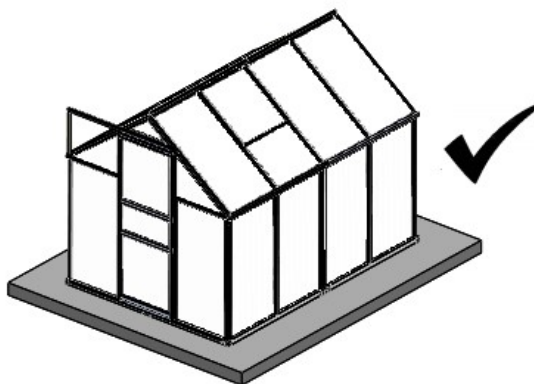

D8(4X)

CBJ14(4X)

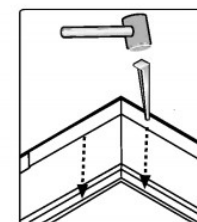
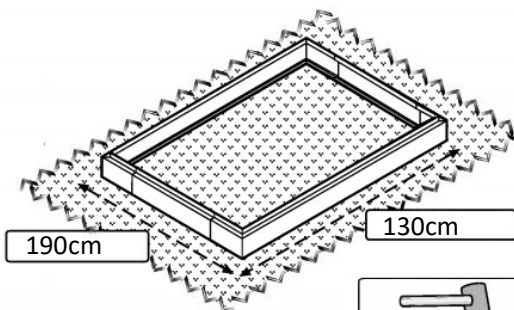

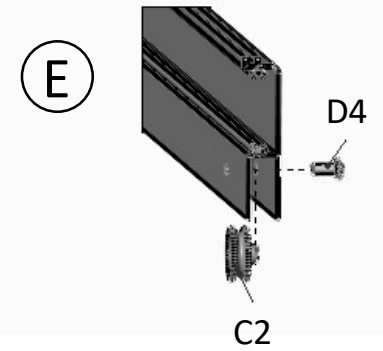
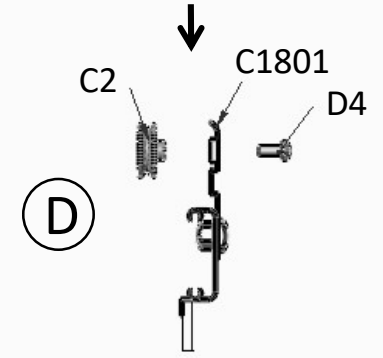
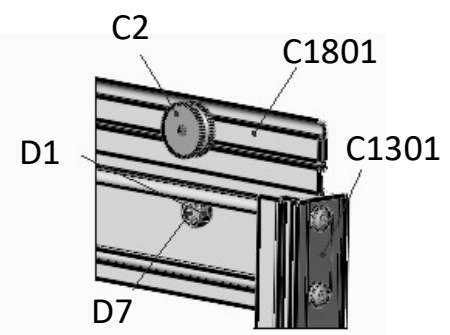
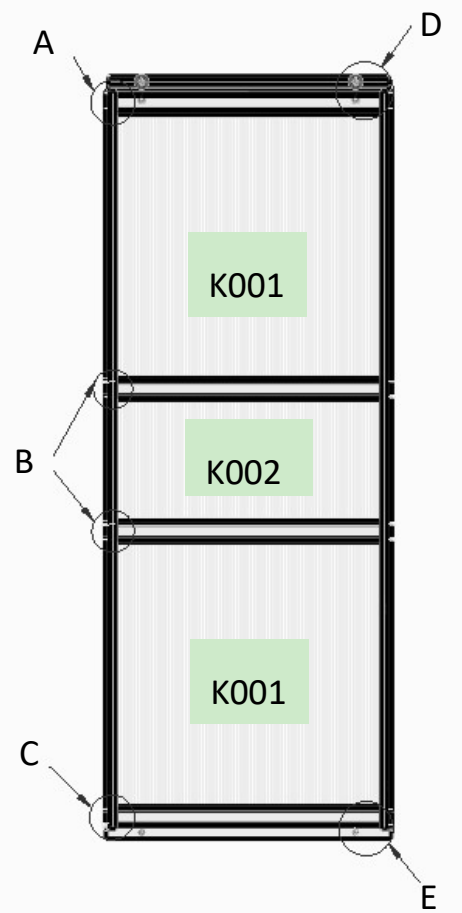
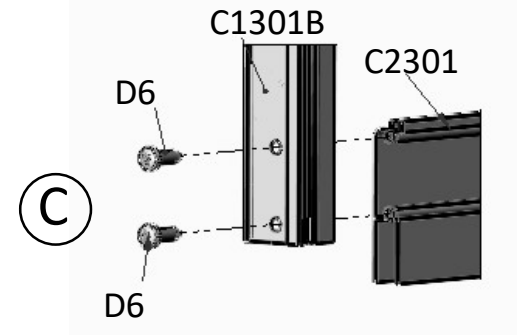
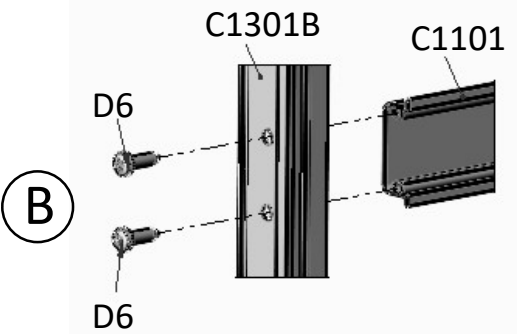
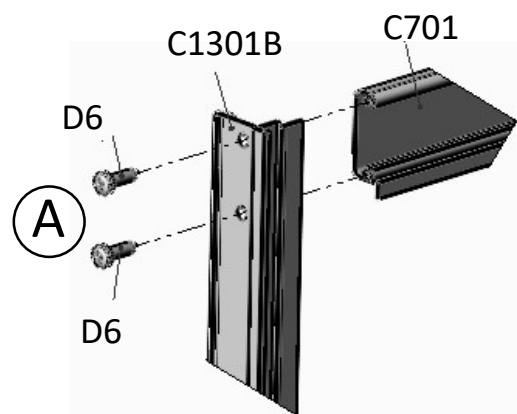



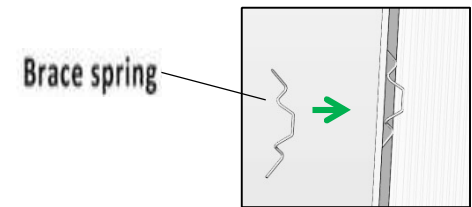

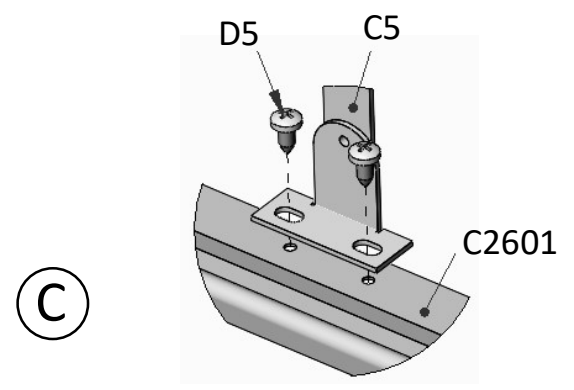
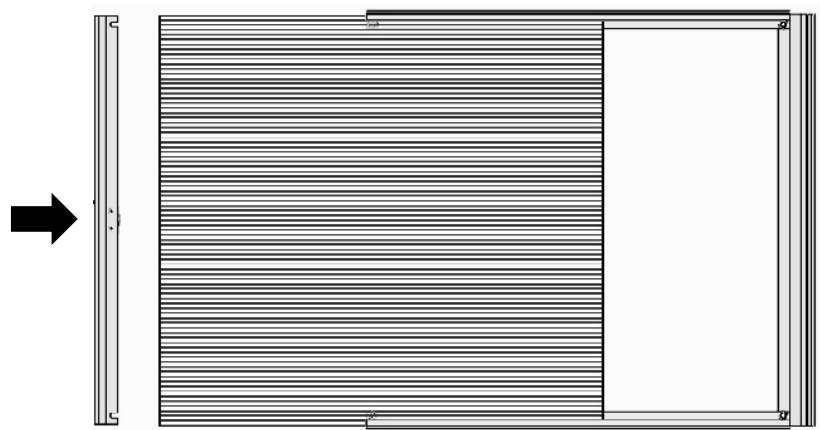
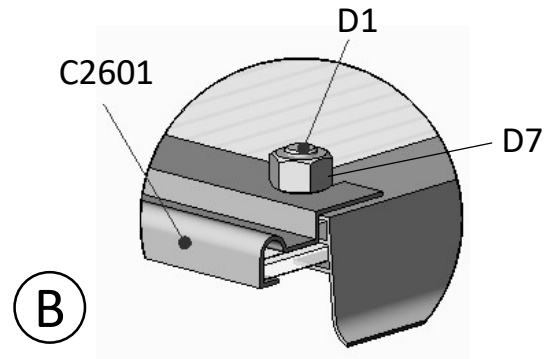
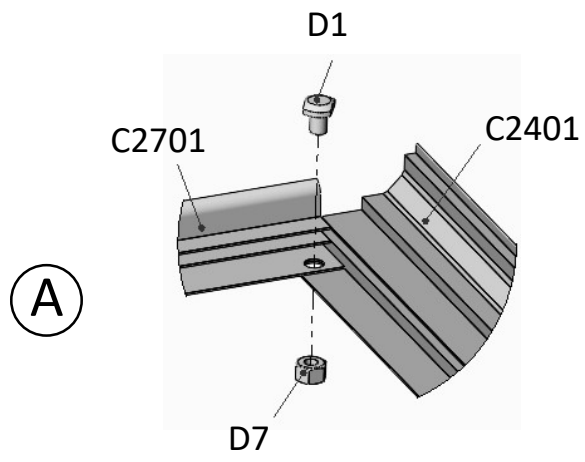
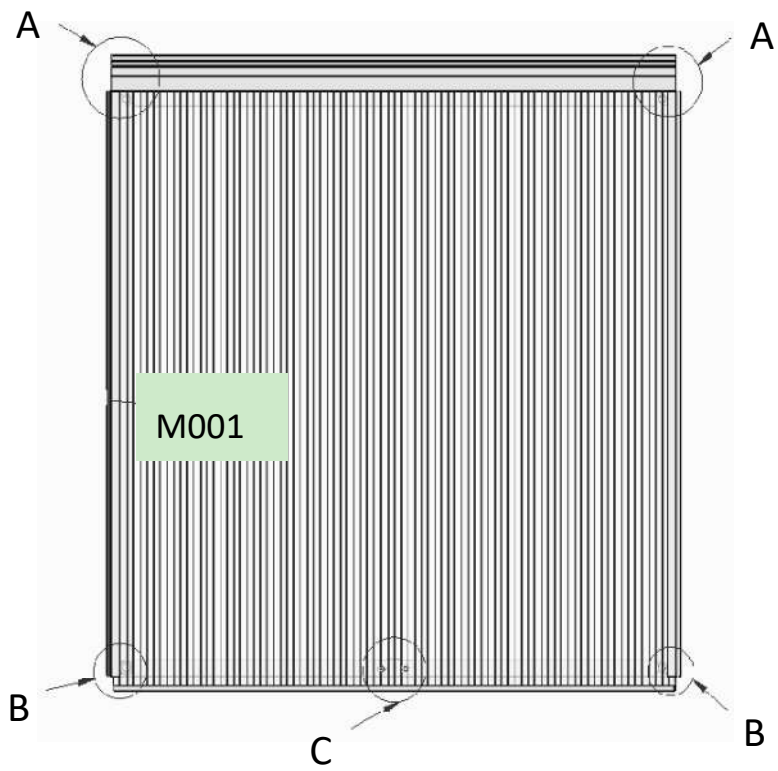



MODEL	CODE	LENGTH(mm)	QTY
	C1301A	1551	1
	C1301B	1551	1
	C1801	590	1
	C701	600	1
	C1101	600	2
	C2301	600	1
	C2		4
	D6	ST4. 8X19	16
	D4	M4X10	4
	K001	562*598	2
	K002	261*598	1
	C4		10
	D1	M6X9*3.5	2
	D7	M6-GB41	2





MODEL	CODE	LENGTH(mm)	QTY
	C2401	607	2
	C2601	602	2
	C2701	600	4
	C5	332	1
	D5	ST4. 2X9. 5	4
	M001	628*604	2
	D1	M6X9*3. 5	8
	D7	M6-GB41	8

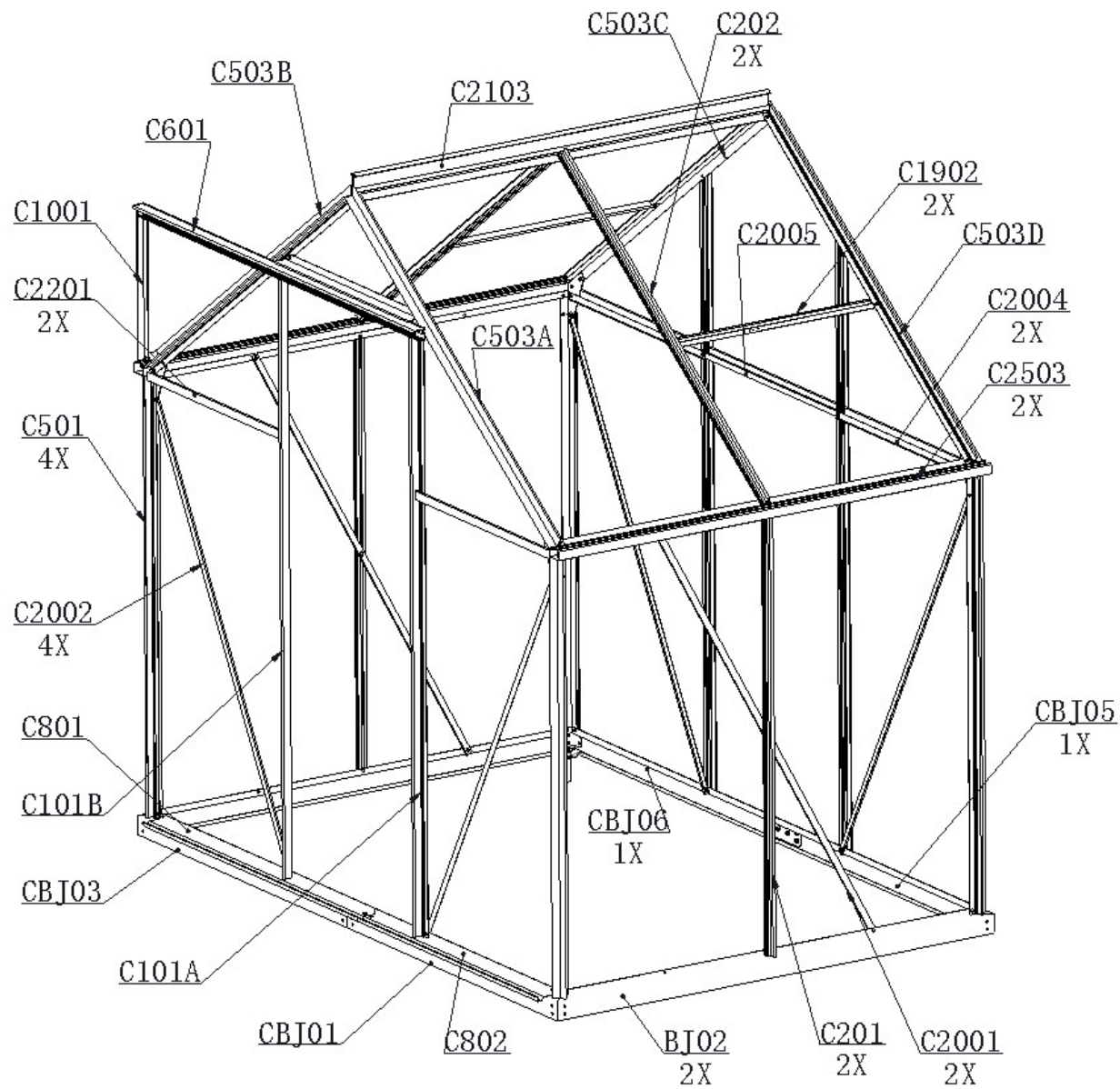

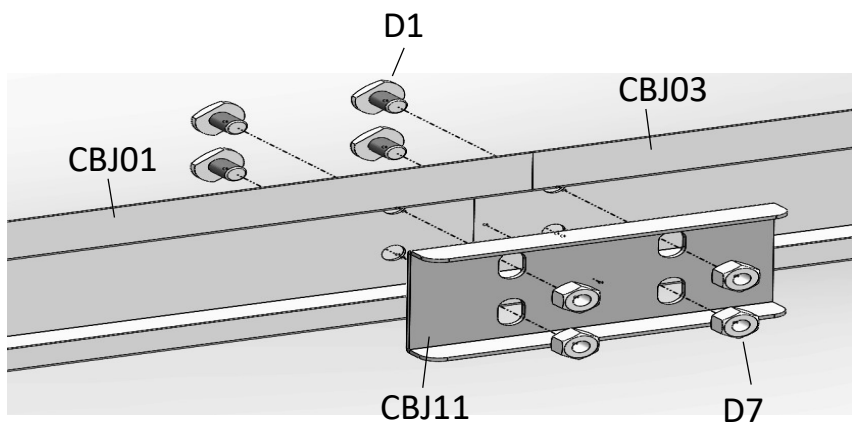



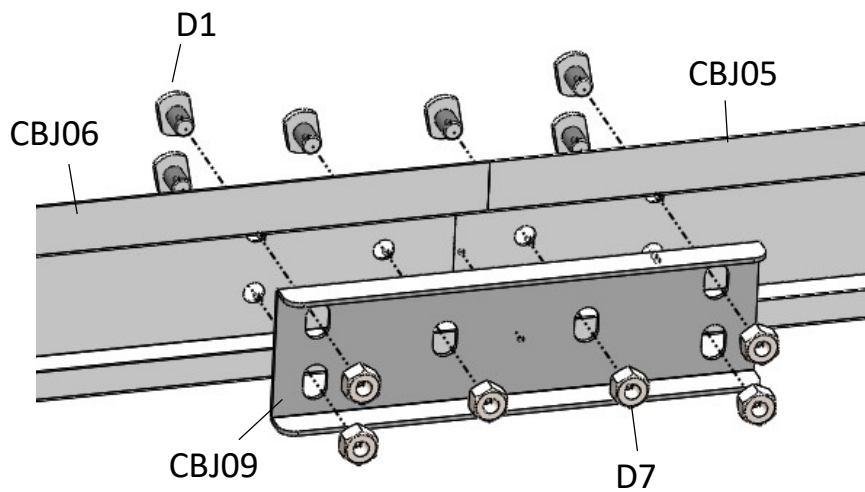

(B1)

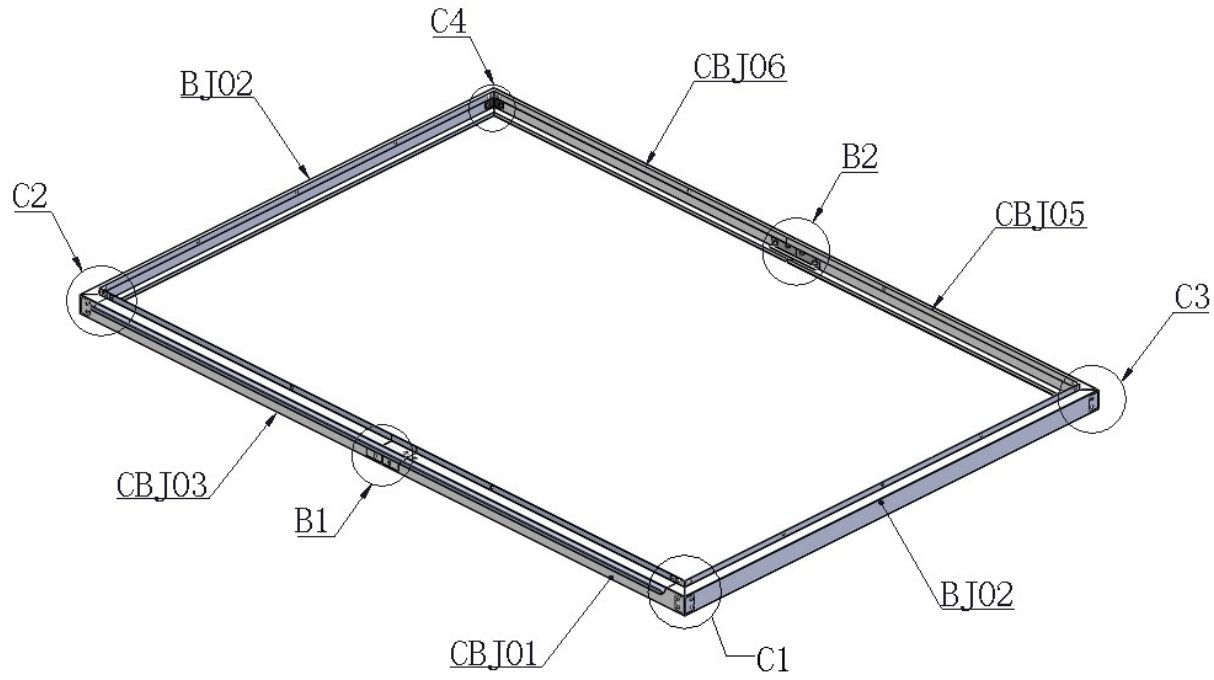

(B2)

MODEL	CODE	LENGTH(mm)	QTY
	CBJ01	948.8	1
	CBJ03	948.8	1
	CBJ05	948.8	1
	CBJ06	948.8	1
	BJ02	1299.2	2
	CBJ09	150*44	1
	CBJ11	100*44	1
	D1	M6X9*3.5	10
	D7	M6-GB41	10



MODEL	CODE	LENGTH(mm)	QTY
	CBJ10	30*40	4
	D1	M6X9*3.5	16
	D7	M6-GB41	16

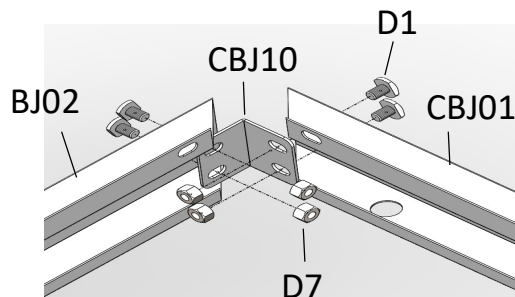

(C1)

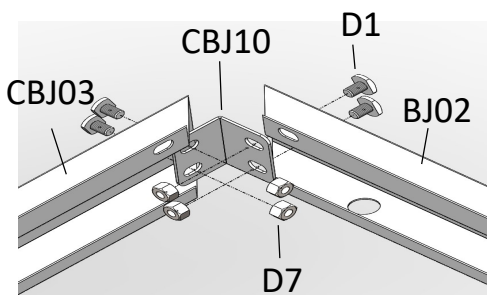



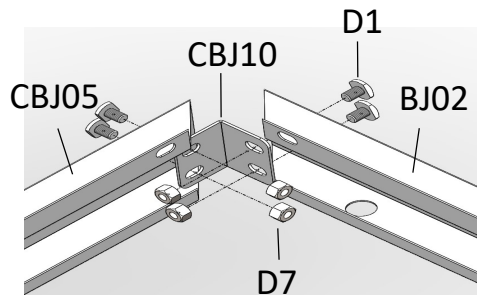

(C2)

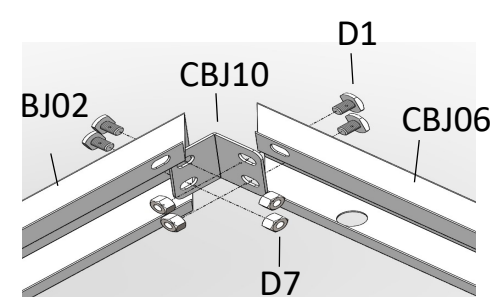

(C3)



(C4)

MODEL	CODE	LENGTH(mm)	QTY
	C801	971.3	1
	C802	815.9	1
	D1	M6X9*3.5	4
	D7	M6-GB41	4

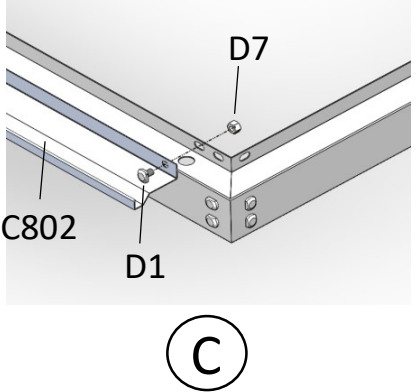
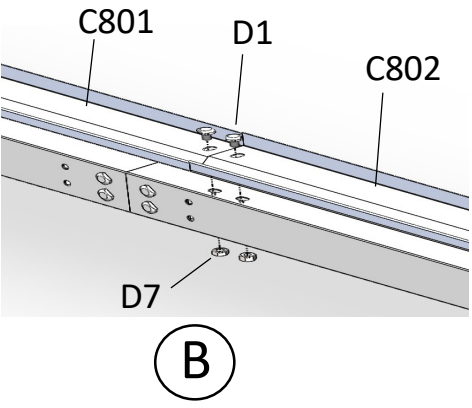
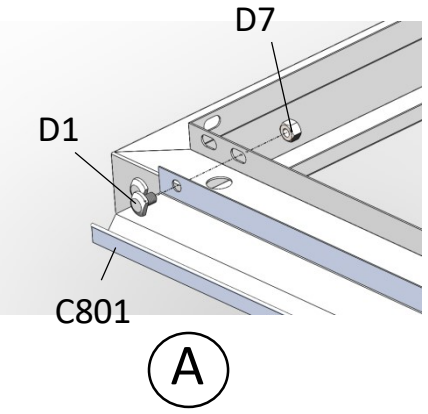
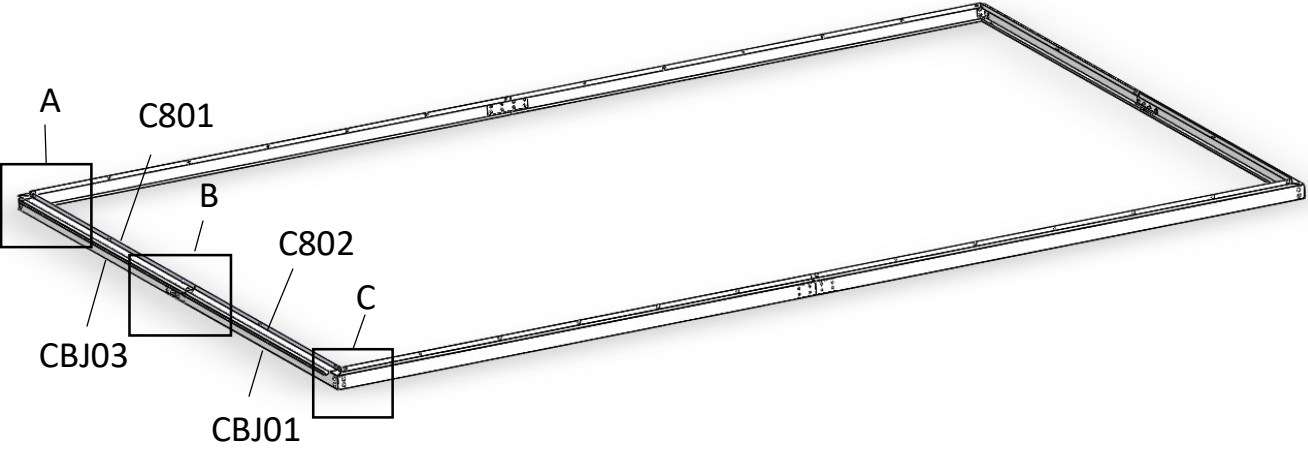

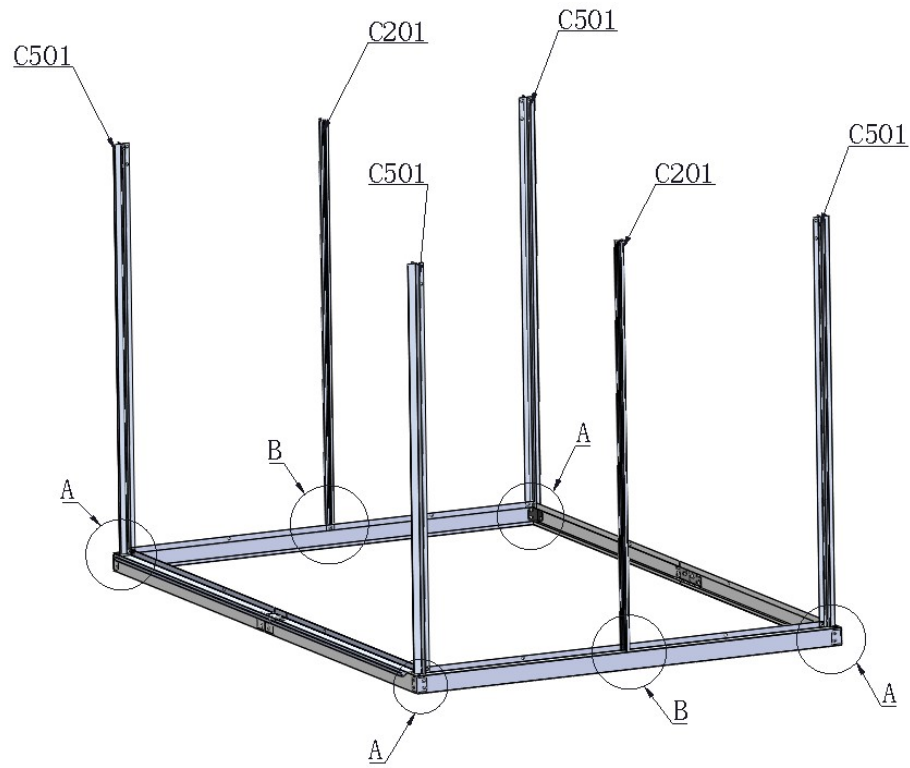

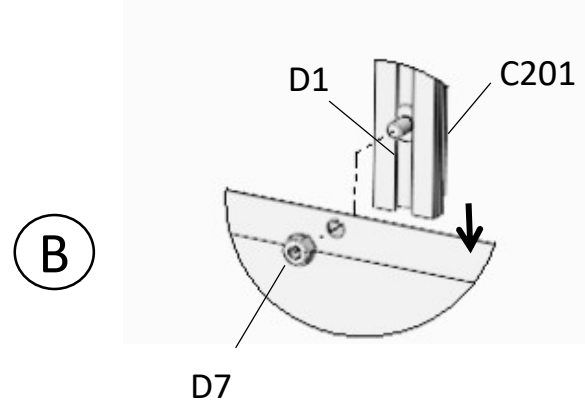
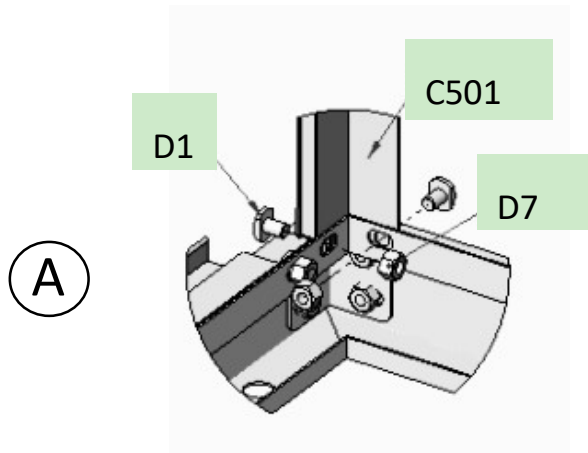

MODEL	CODE	LENGTH(mm)	QTY
	C501	1150	4
	C201	1150	2
	D1	M6X9*3.5	10
	D7	M6-GB41	10

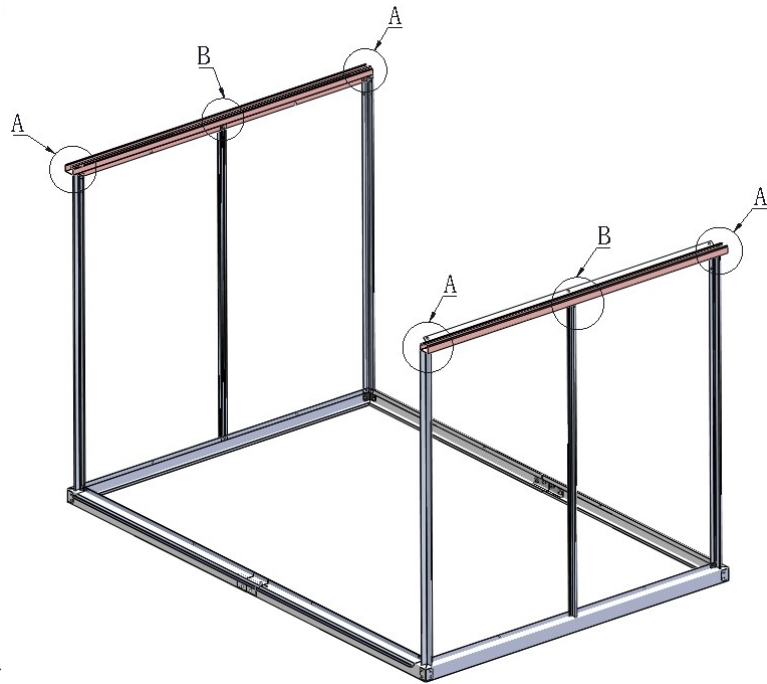



MODEL	CODE	LENGTH(mm)	QTY
	D7	M6-GB41	6
	D1	M6X9*3.5	8
	C2503	1286.2	2

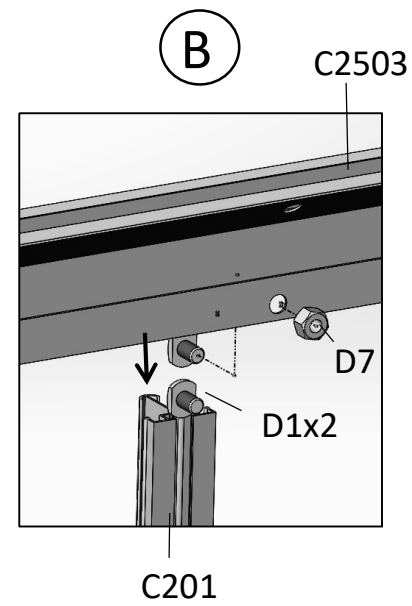
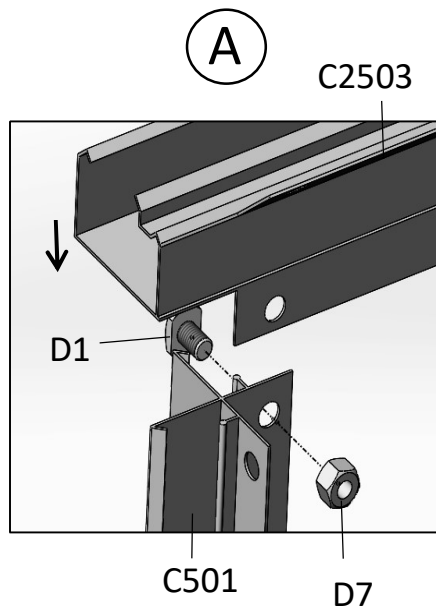

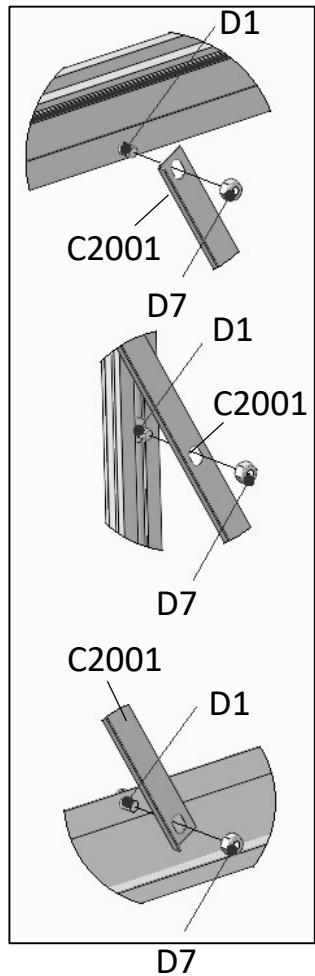
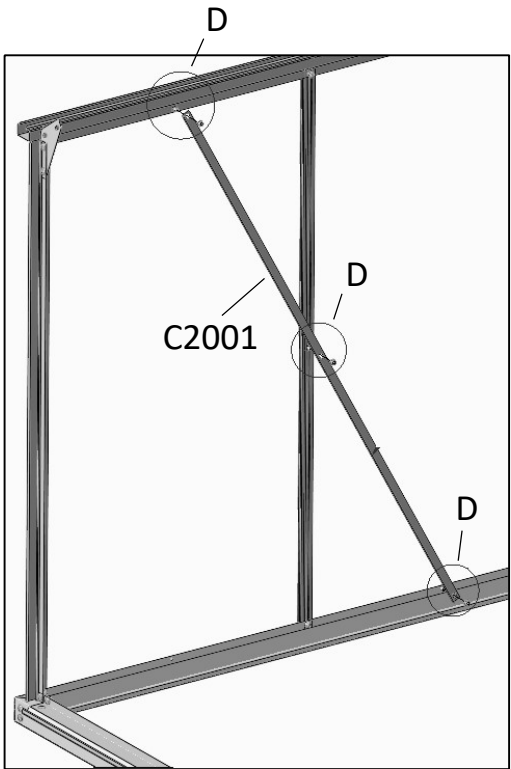

f



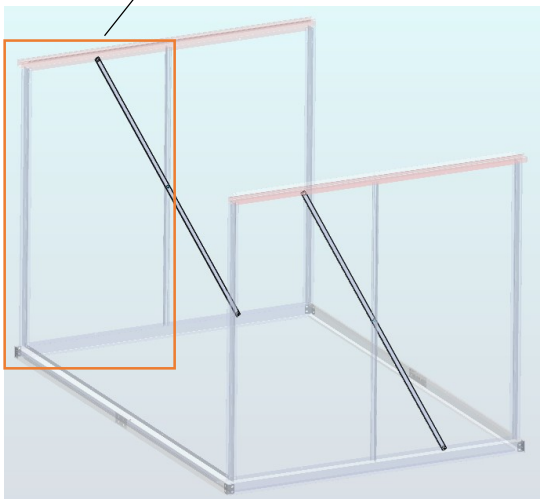

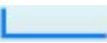



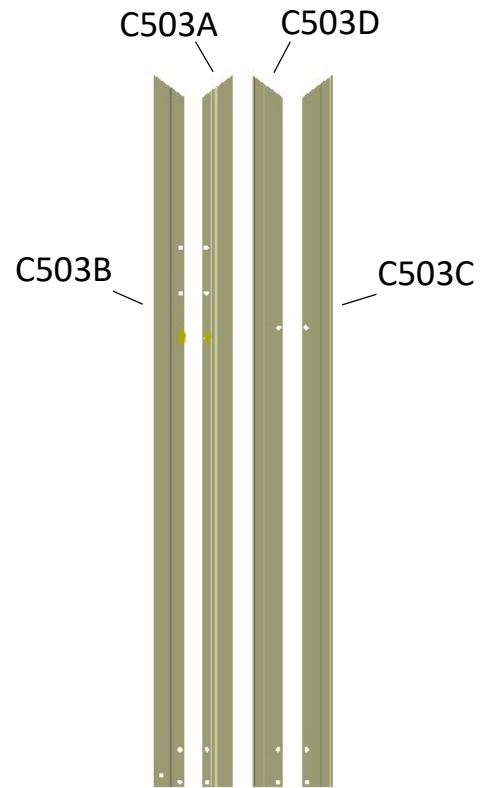
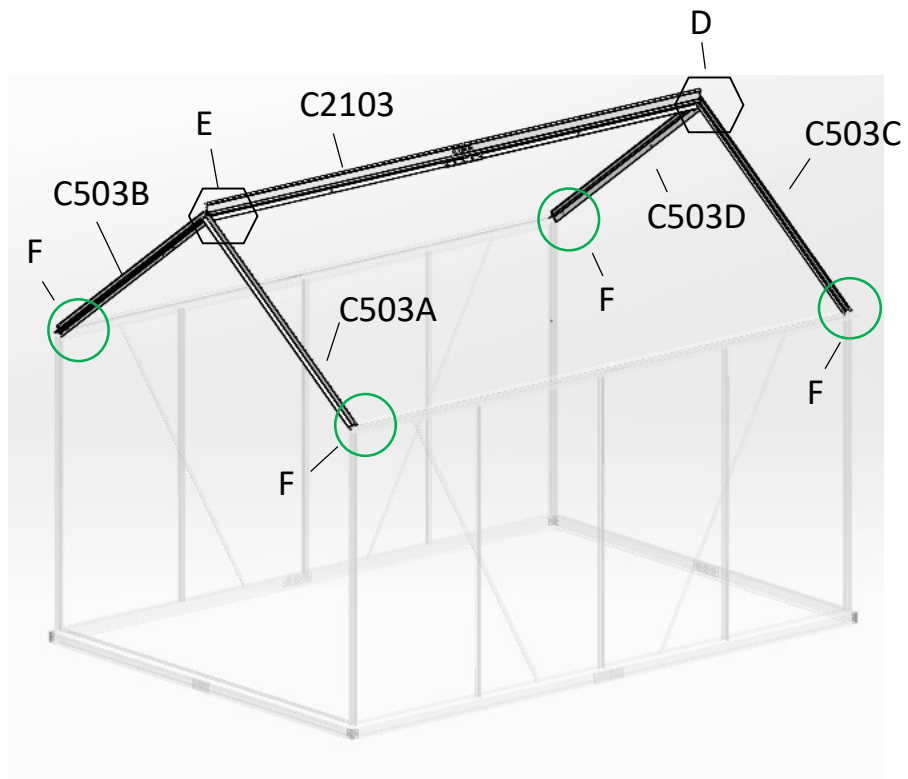

(D)



MODEL	CODE	LENGTH(mm)	QTY
	G2001	1310	2
	D1	M6X9*3.5	4
	D7	M6-GB41	6



MODEL	CODE	LENGTH(mm)	QTY
	C503A	1157	1
	C503B	1157	1
	C503C	1157	1
	C503D	1157	1
	C2103	1234.2	1
	CBJ07	138*69	4
	D1	M6X9*3.5	20
	D7	M6-GB41	20

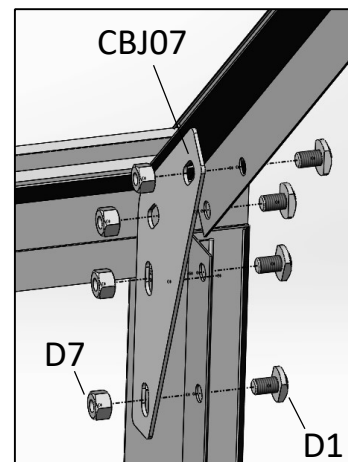
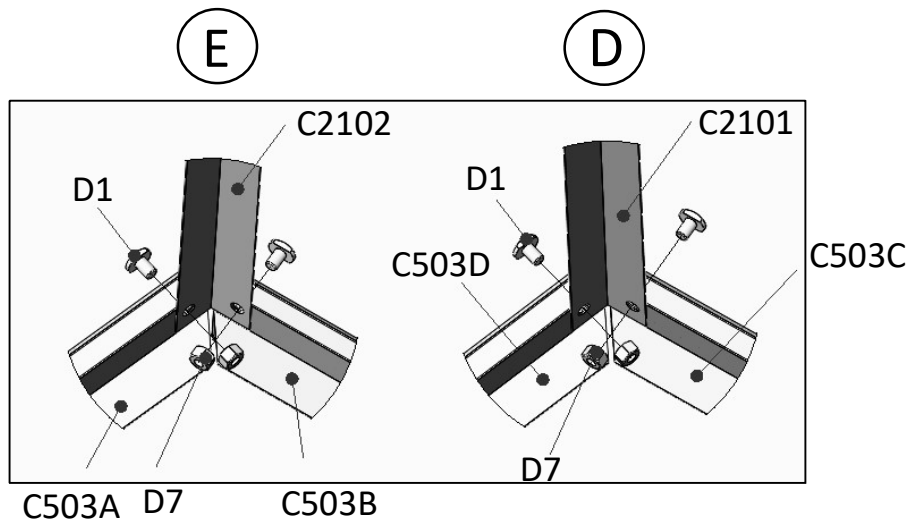

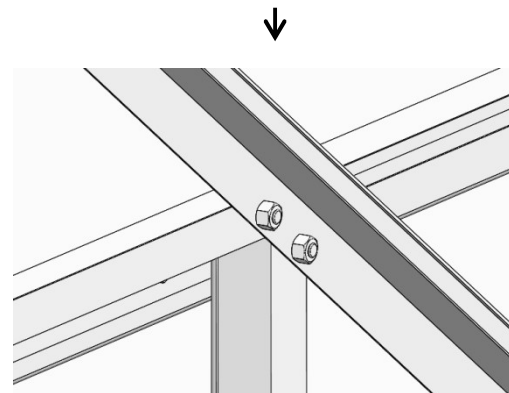
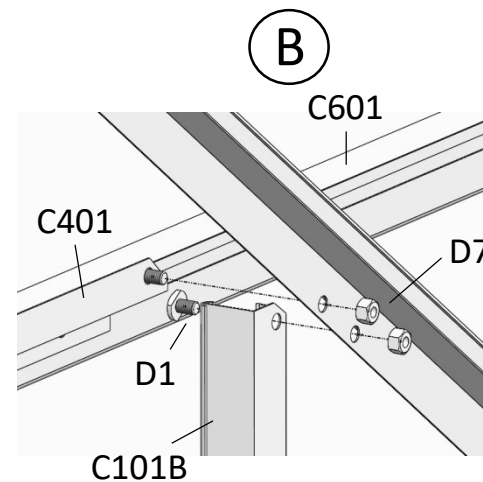
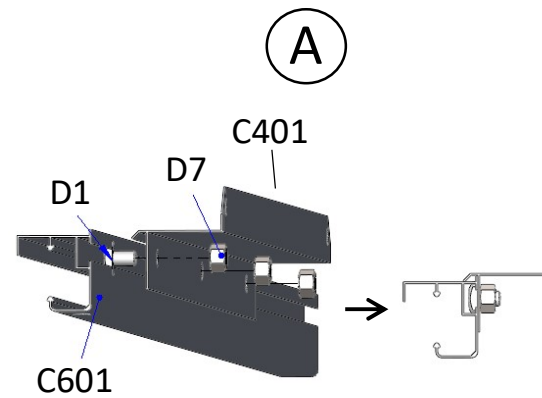
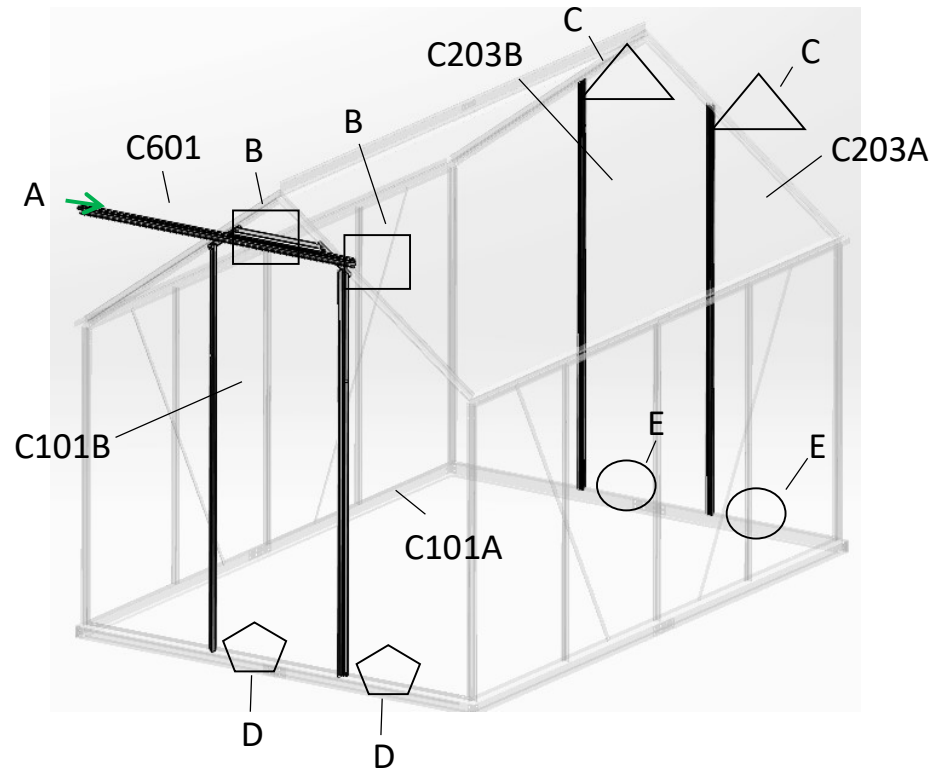

MODEL	CODE	LENGTH(mm)	QTY
	C601	1275	1
	C101A	1606	1
	C101B	1606	1
	C401	606	1
	C203A	1622	1
	C203B	1622	1
	D1	M6X9*3.5	15
	D7	M6-GB41	13

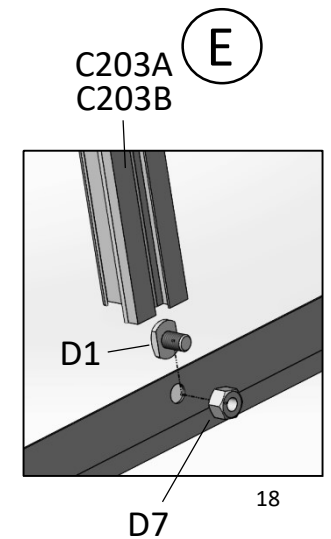
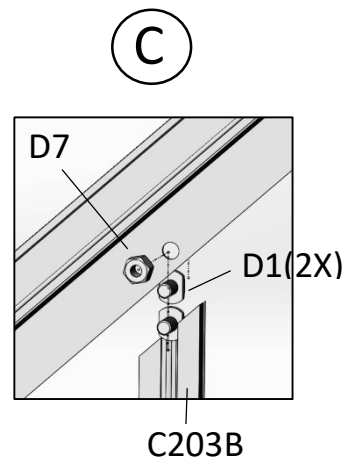
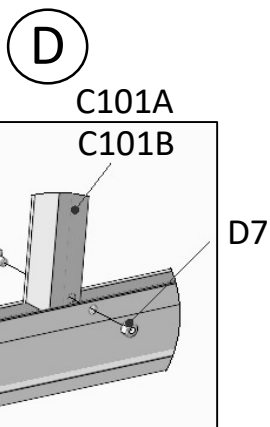

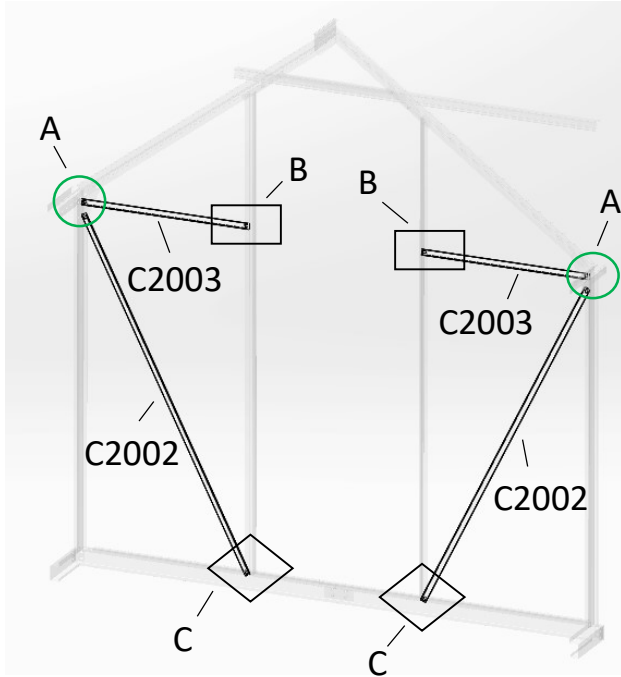

A

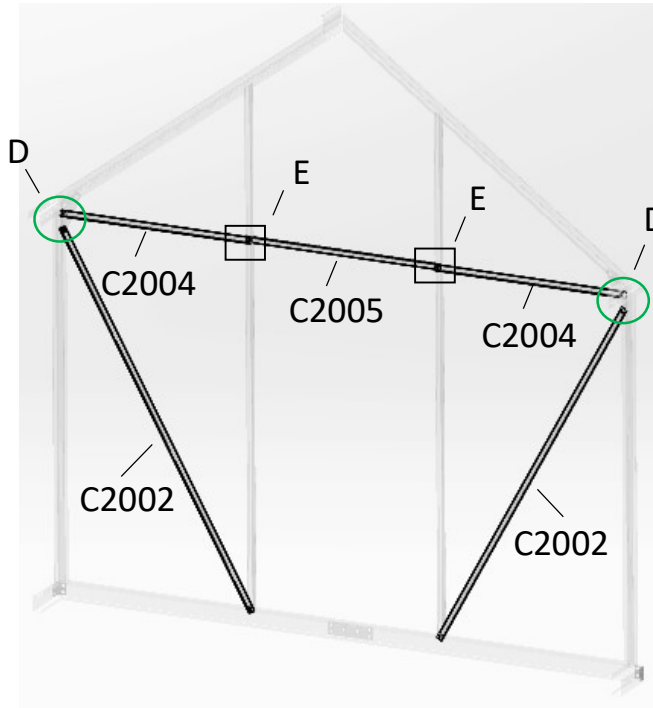

B

MODEL	CODE	LENGTH(mm)	QTY
	C2002	1253	4
	C2003	610	2
	C2004	616	2
	C2005	635	1
	D1	M6X9*3.5	2
	D7	M6-GB41	4

E

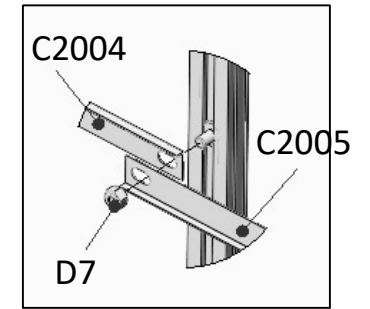

D

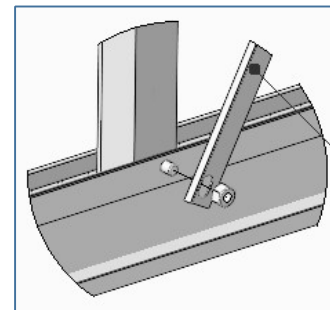
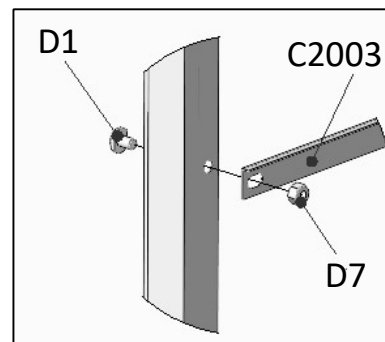
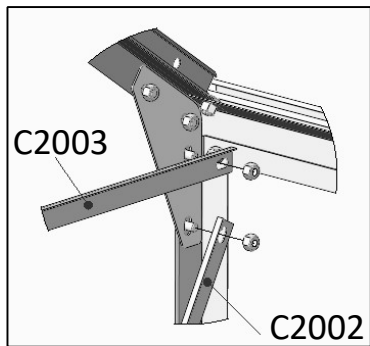

C2002

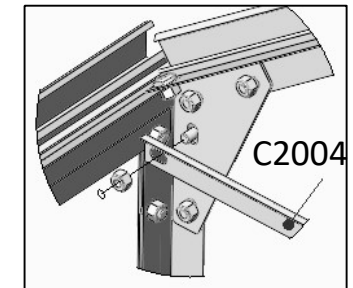

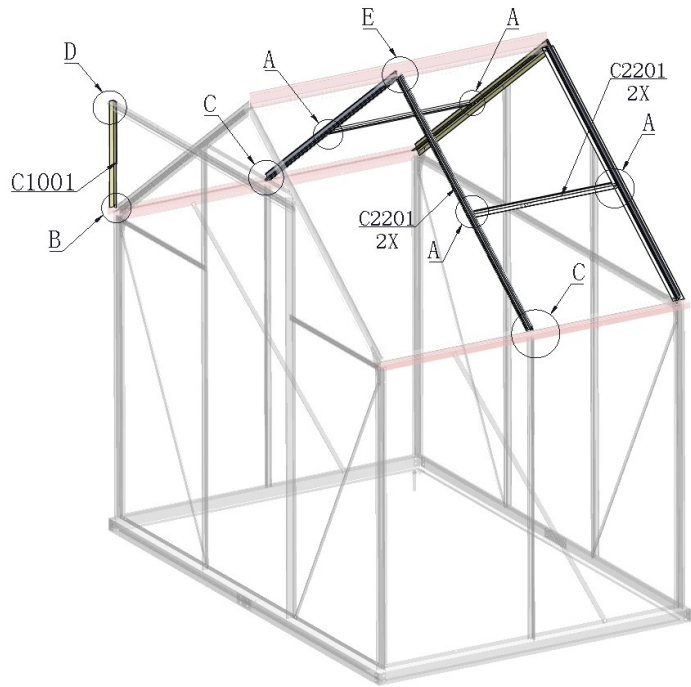

(A)

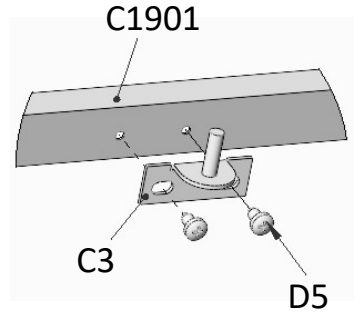
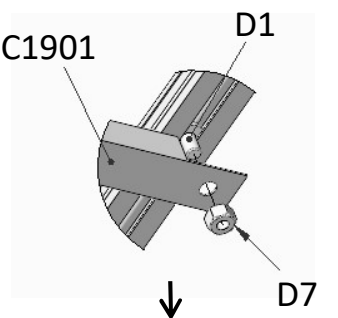

(B)

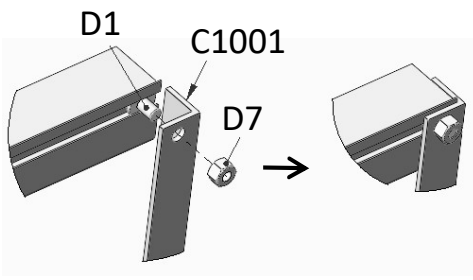

(D)

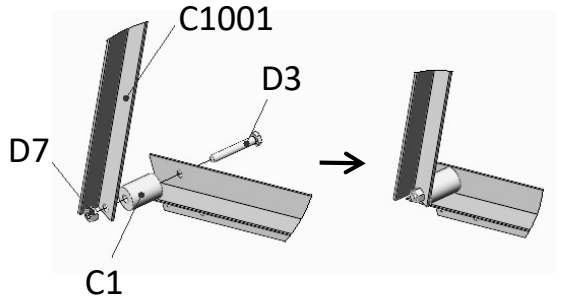

(E)

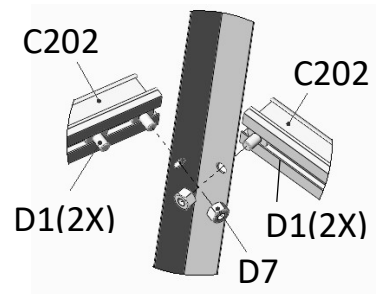

SlideScrew into F in advance: D1(2x)

(C)

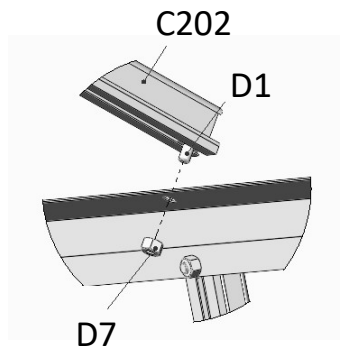

MODEL	CODE	LENGTH(mm)	QTY
	C1902	628	2
	C202	1137	2
	C1001	405.5	1
	C3		2
	C1	28	1
	D3	M6X40	1
	D5	ST4. 2X9.5	4
	D1	M6X9*3.5	9
	D7	M6-GB41	10

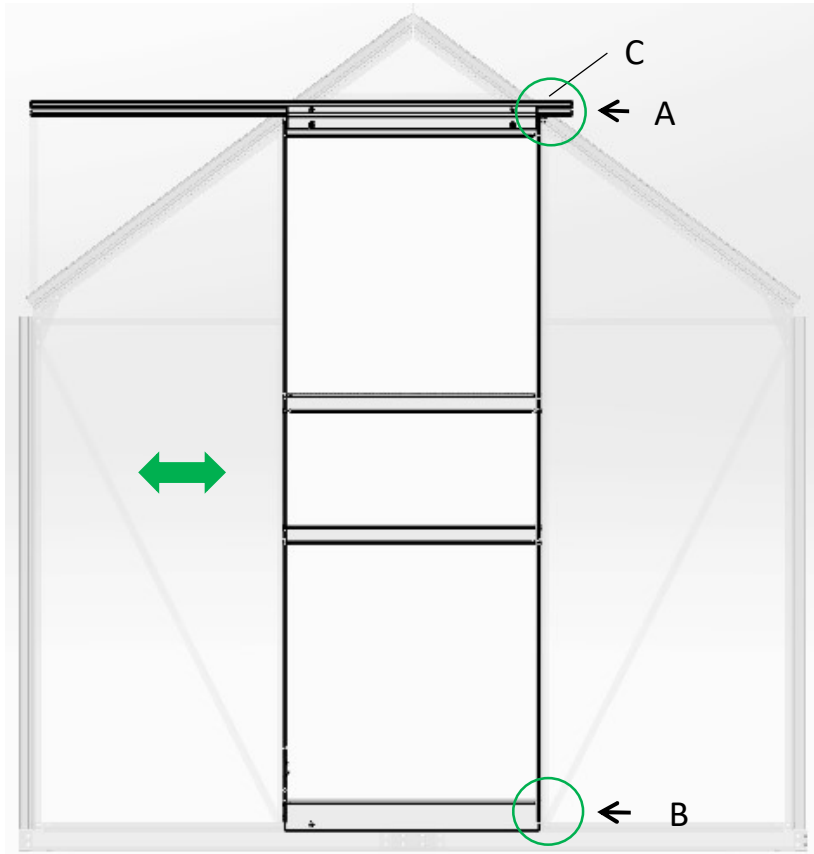

MODEL	CODE	LENGTH(mm)	QTY
	D2	M6X16	1
	D7	M6-GB41	1

(A)

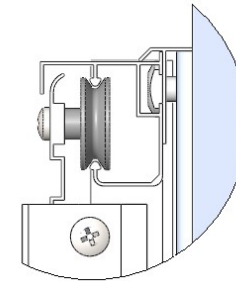

(B)

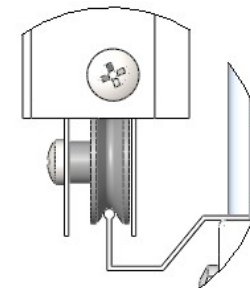

(C)

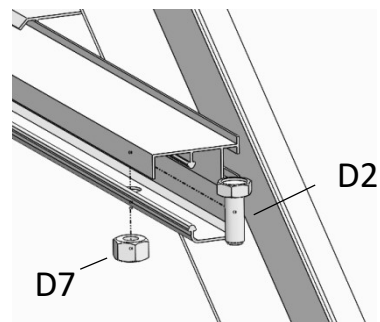

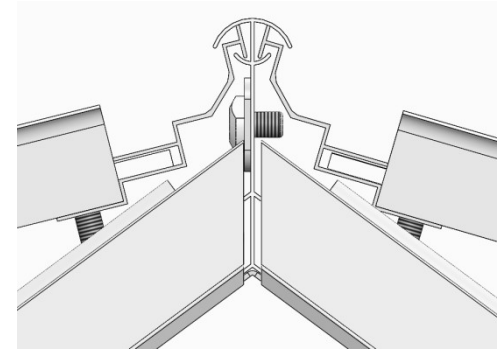
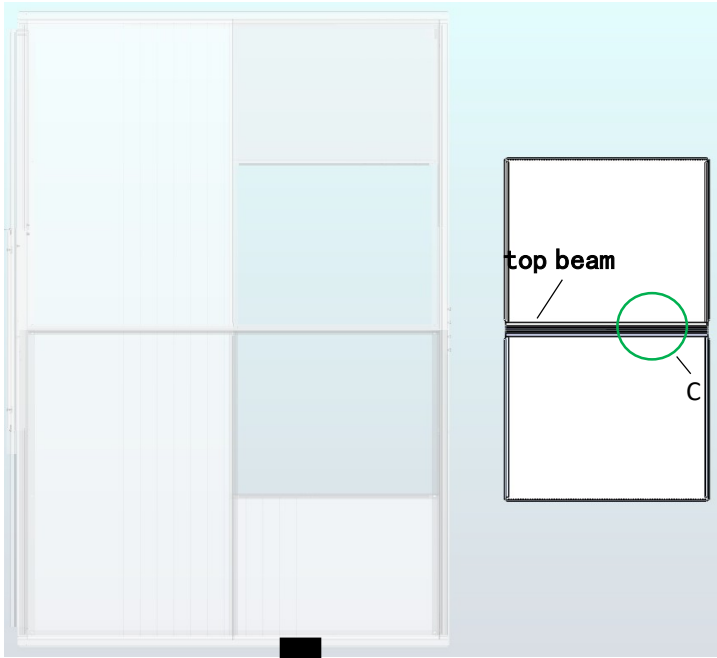

Back

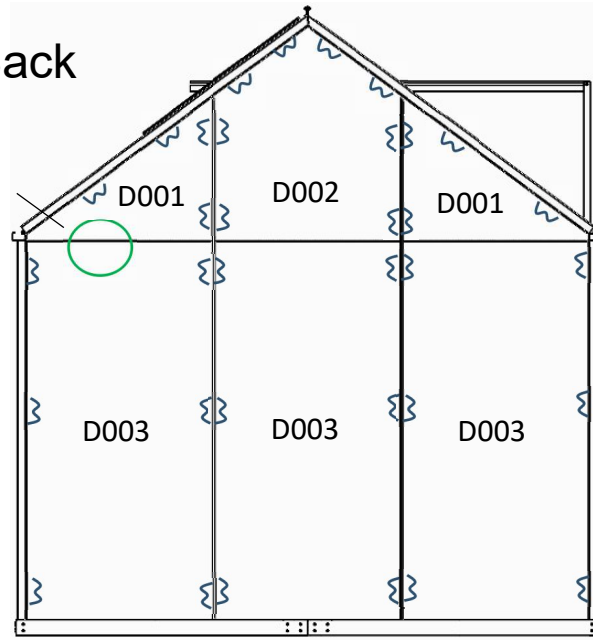



C2202



E

Right

MODEL	CODE	LENGTH(mm)	QTY
	G2201	621	2
	G2202	610	3
	C4		120

Left

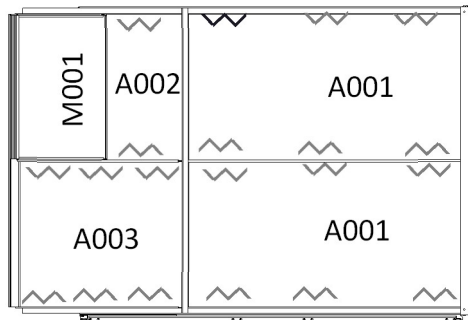

C2201



F

Front

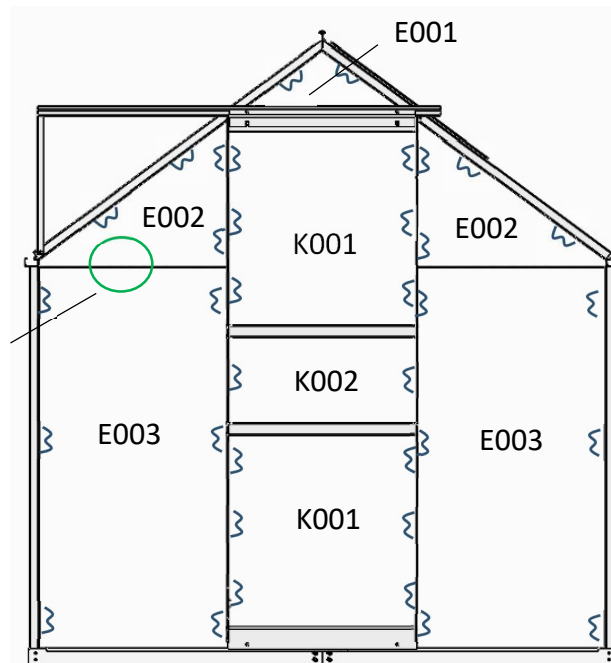
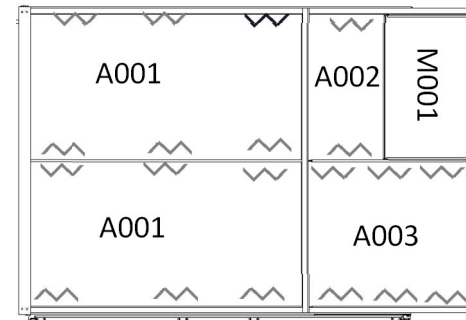

Note: First PC board is assembled into aluminum part. Then place spring on the outer surface against PC board as installation direction shown in below diagram

